



D 5.1 ProGraph

Sheet gasket from expanded graphite with tanged stainless steel foil reinforcement

Characteristics

- Graphite gasket reinforced with a 0.1 mm tanged stainless steel insert and a purity of 98 %.
- Practically no cold flow or creep under temperature
- Excellent in use at cycling temperatures
- High blow out safety
- Built in safety against assembly and operational problems.

Operating range

p_{max} [bar]	100
$t^{\circ}C$	-200 ... +550
pH	0 - 14

Temperature: in oxidizing atmosphere
+450 °C

Main application

Robust graphite gasket applicable
in all industries and as well
approved to seal older equipment.

Suitable for

- In all industries

Approvals

- BAM
- DVGW
- KTW

Form of delivery

- Gasket sheet size of 1,000 x 1,000 mm in thickness of 0.5 / 1.0 / 1.5 / 2.0 / 3.0 mm or cut gaskets according to drawing, or EN and international Standards.
- Special dimensions on request.



All technical information and advice is based on our experience and will be given most conscientiously but without any liability.

Indication and figures are for guidance only and need to be examined by the user. All sizes are subject to manufacturing tolerances. We reserve the right to modify specifications at any time.

Please note that the technical values cannot be used all at the same time in their maximum values.

ProPack AG

Rudolf-Diesel-Ring 28 . 82054 Sauerlach

Fon ++49 (0) 8104 6640 0 . Fax ++49 (0) 8104 6640 44

propack@propack.ag

www.propack.ag

TECHNOLOGY MADE IN GERMANY



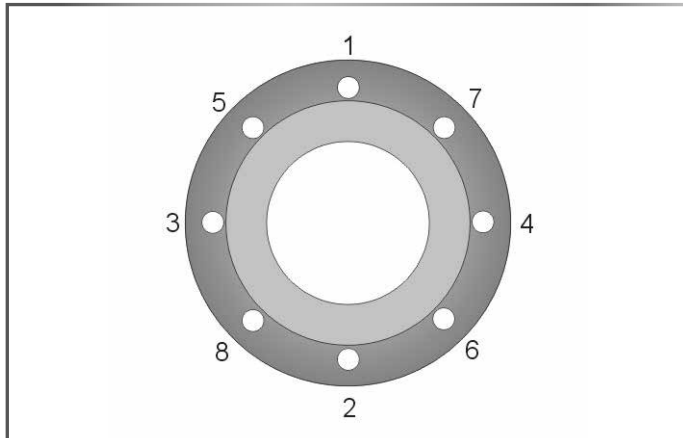

Installation

Clean sealing surface completely. Remove any dirt, corrosion, grease or remainders from old sealing materials.

- Position gasket centric on the sealing surface. Take extra care on vertical assemblies. First tighten bolts finger-tight.

Then continue at least with 4 progressive torque sequences with a torque wrench, always torque crosswise as shown in the sketch (see fig. 1). Apply 25%, 50%, 75% and 100% of the recommended gasket stress.

- Always follow the state-of-the-art guidelines for gasket assembly as well as the recommended torque for your sealing system.

- Notes of the flange manufacturer and recommended torques for the sealing system (flange, bolt, gasket) need to be followed.

Gasket sheets technical data

	Compressibility ASTM F36 %	Recovery ASTM F36 %	PQR EN13555	Pressure* max* bar	Temp (Material)* max* °C	Material	Q _{min} EN13555 (MPa)	Q _{Smin} EN13555 (MPa)	Q _{Smax} EN13555 (MPa)
D 5.1 ProGraph	35	17	0.96 @ 300 °C; QA=50MPa	100	550	expanded graphite with tanged stainless steel foil	55	10	220

*The max values of pressure and temperature cannot be used at the same time

The provided Pressure and Temperature data is based on optimal installation condition and steady control of the flange connection

Gasket properties following EN 13555 (2 mm thickness) Q_{min}@40 bar He, 0.01 mg/(ms) and Q_{Smin}@QA 40 Mpa He, L=0.01

(1) Q_{Smin} @ QA 40 MPa, 40 bar He, L=0.01

(2) Q_{Smin} @ QA 60 MPa, 40 bar He, L=0.01

Q_{Smax} @ RT

All technical information and advice is based on our experience and will be given most conscientiously but without any liability.

Indication and figures are for guidance only and need to be examined by the user. All sizes are subject to manufacturing tolerances. We reserve the right to modify specifications at any time.

Please note that the technical values cannot be used all at the same time in their maximum values.