



D 3.5 ProFlon Fawn

Modified PTFE reinforced with special silica filler

Characteristics

- Protected against cold flow
- Excellent recovery
- Very good in applications with varying temperatures
- Reduced leakage rates compared to other filled PTFE gaskets under the same gasket stress.

Operating range

p_{max} [psi]	1090
t °F	-350 ... +500
pH	0 - 14

Recommended operating range: Vacuum up to 800 psi, from ambient -360 °F up to +450 °F

Main application

- Steel or other metal flanges on pipework
- Vessel
- Container
- Reactors in higher temperature applications.

Suitable for

- Chemical and Petrochemical industry

Approvals

- TA-Luft VDI 2440 and VDI 2290
- FDA



Article code / Thickness

D 3.5 FAWN 05 / 0.5 mm / 0.02"
D 3.5 FAWN 10 / 1.0 mm / 0.04"
D 3.5 FAWN 15 / 1.5 mm / 0.06"
D 3.5 FAWN 20 / 2.0 mm / 0.08"
D 3.5 FAWN 30 / 3.0 mm / 0.12"

Form of delivery

Gasket sheet size of 60" x 60" in thickness of 0.02"/0.04"/0.06"/0.08"/0.12" or cut gaskets according to drawing, or EN and international Standards, special dimensions on request.



Electron microscopic view

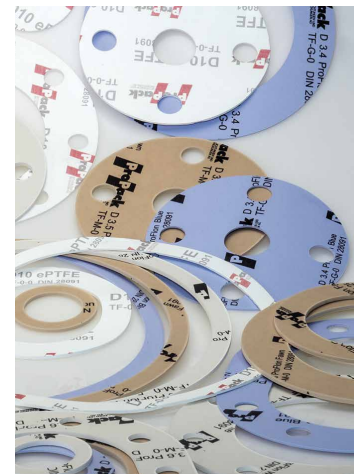

All technical information and advice is based on our experience and will be given most conscientiously but without any liability.

Indication and figures are for guidance only and need to be examined by the user. All sizes are subject to manufacturing tolerances. We reserve the right to modify specifications at any time.

Please note that the technical values cannot be used all at the same time in their maximum values.

ProPack AG

Rudolf-Diesel-Ring 28 . 82054 Sauerlach . Germany

Phone ++49 (0) 8104 6640 0 . Fax ++49 (0) 8104 6640 44

propack@propack.ag

www.propack.ag

TECHNOLOGY MADE IN GERMANY

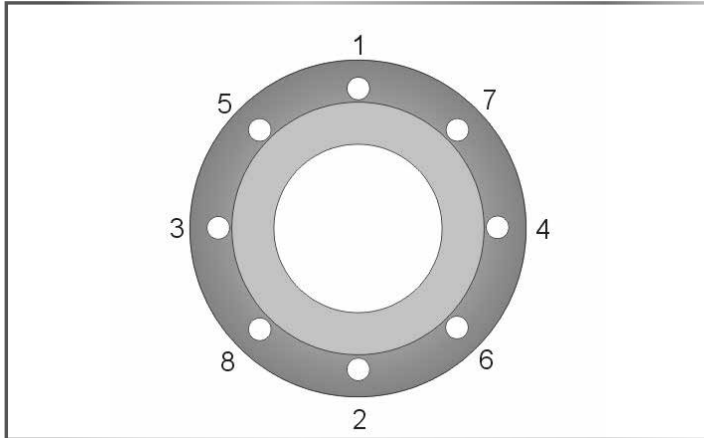

Installation

Clean sealing surface completely. Remove any dirt, corrosion, grease or remainders from old sealing materials.

- Position gasket centric on the sealing surface. Take extra care on vertical assemblies. First tighten bolts finger-tight.

Then continue at least with 4 progressive torque sequences with a torque wrench, always torque crosswise as shown in the sketch (see fig. 1). Apply 25%, 50%, 75% and 100% of the recommended gasket stress.

- Always follow the state-of-the-art guidelines for gasket assembly as well as the recommended torque for your sealing system.

- Notes of the flange manufacturer and recommended torques for the sealing system (flange, bolt, gasket) need to be followed.

Gasket sheets technical data

	Compressibility ASTM F36 %	Recovery ASTM F36 %	PQR EN13555	Pressure* max* psi	Temp (Material)* max* °F	Material	Q _{min} EN13555 (MPa)	Q _{Smin} EN13555 (MPa)	Q _{Smax} EN13555 (MPa)
D 3.5 ProFlon Fawn	12	>40	0.73 @ 302 °F; 30MPa	1090	500	sPTFE with SiO ₂	16	<10	120

*The max values of pressure and temperature cannot be used at the same time Recommended operating range Vacuum to 800 psi, from ambient -360 °F to + 450 °F

The provided Pressure and Temperature data is based on optimal installation condition and steady control of the flange connection

Gasket properties following EN 13555 (2 mm / 0.08" thickness)

Q_{min} @ 580 psi He, 0.01 mg/(ms) and

Q_{Smin} @ QA = 40 Mpa; 580 psi He, L=0.01

Q_{Smax} @ RT

All technical information and advice is based on our experience and will be given most conscientiously but without any liability.

Indication and figures are for guidance only and need to be examined by the user. All sizes are subject to manufacturing tolerances. We reserve the right to modify specifications at any time.

Please note that the technical values cannot be used all at the same time in their maximum values.

ProPack AG

Rudolf-Diesel-Ring 28 . 82054 Sauerlach . Germany

Phone ++49 (0) 8104 6640 0 . Fax ++49 (0) 8104 6640 44

propack@propack.ag

www.propack.ag

TECHNOLOGY MADE IN GERMANY

