

## D 2.0 Allround

General Service Aramid Fiber based gasket with anorganic filler and NBR binder.

### Characteristics

- Standard Gasket for plant wide use with good thermal and mechanical properties as well a wide chemical compatibility
- Do not use any surface treatment!

### Operating range

$p_{max}$ [psi]	1450
$t^{\circ}F$	-60 ... +480

Temperature: short term up to 570 °F

### Main application

- Tube and pipe flanges
- Vessels
- Boilers
- Cylinders
- Joints
- Casings
- Lids

### Suitable for

- All Industries

### Approvals

- DVGW
- KTW
- BAM
- TA Luft (VDI2440)
- WRAS

### Form of delivery

Gasket sheet size of 60" x 60" in thickness of 0.01" / 0.02" / 0.03" / 0.04" / 0.06" / 0.08" / 0.12" / 0.16" or cut gaskets according to drawing, or EN and international Standards.

Special dimensions and further gasket material styles from recognised manufacturers on request.



All technical information and advice is based on our experience and will be given most conscientiously but without any liability.

Indication and figures are for guidance only and need to be examined by the user. All sizes are subject to manufacturing tolerances. We reserve the right to modify specifications at any time. Please note that the technical values cannot be used all at the same time in their maximum values.

### ProPack AG

Rudolf-Diesel-Ring 28 . 82054 Sauerlach . Germany

Phone ++49 (0) 8104 6640 0 . Fax ++49 (0) 8104 6640 44  
propack@propack.ag

[www.propack.ag](http://www.propack.ag)  
TECHNOLOGY MADE IN GERMANY

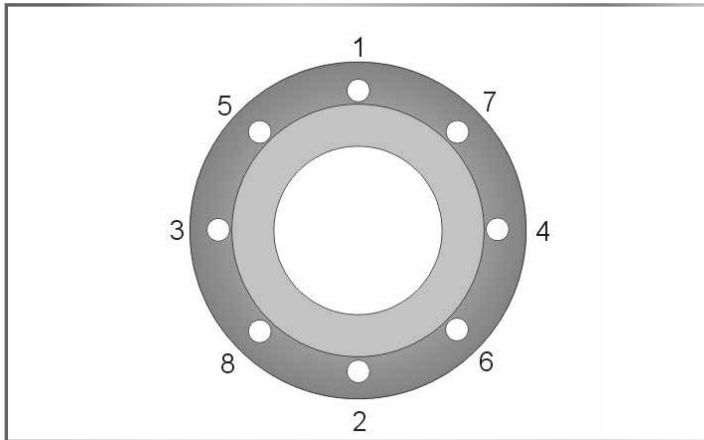

### Installation

Clean sealing surface completely. Remove any dirt, corrosion, grease or remainders from old sealing materials.

- Position gasket centric on the sealing surface. Take extra care on vertical assemblies. First tighten bolts finger-tight.

Then continue at least with 4 progressive torque sequences with a torque wrench, always torque crosswise as shown in the sketch ( see fig. 1 ). Apply 25%, 50%, 75% and 100% of the recommended gasket stress.

- Always follow the state-of-the-art guidelines for gasket assembly as well as the recommended torque for your sealing system.

- Notes of the flange manufacturer and recommended torques for the sealing system ( flange, bolt, gasket ) need to be followed.

### Gasket sheets technical data

	Compressibility ASTM F36 %	Recovery ASTM F36 %	PQR EN13555	Pressure <sup>*</sup> max <sup>*</sup> psi	Temp (Material) <sup>*</sup> max <sup>*</sup> °F	Material	Q <sub>min</sub> EN13555 (MPa)	Q <sub>Smin</sub> EN13555 (MPa)	Q <sub>Smax</sub> EN13555 (MPa)
D 2.0 Allround	11	60	0.83 @ 210 °F; QA=50MPa	1450	480 (390 in steam)	Aramidfiber, NBR, Filler	27	10	220

\*The max values of pressure and temperature cannot be used at the same time

The provided Pressure and Temperature data is based on optimal installation condition and steady control of the flange connection

Gasket properties following EN 13555 (2 mm / 0.08" thickness) Q<sub>min</sub>@580 psi He, 0.01 mg/(ms) and

Q<sub>Smin</sub>@QA 40 Mpa He, L=0.01

(1) Q<sub>Smin</sub> @ QA 30 MPa, 580 psi He, L=0.01

(2) Q<sub>Smin</sub> @ QA 60 MPa, 580 psi He, L=0.01

Q<sub>Smax</sub> @ RT

All technical information and advice is based on our experience and will be given most conscientiously but without any liability.

Indication and figures are for guidance only and need to be examined by the user. All sizes are subject to manufacturing tolerances. We reserve the right to modify specifications at any time.

Please note that the technical values cannot be used all at the same time in their maximum values.

### ProPack AG

Rudolf-Diesel-Ring 28 . 82054 Sauerlach . Germany

Phone ++49 (0) 8104 6640 0 . Fax ++49 (0) 8104 6640 44

propack@propack.ag

[www.propack.ag](http://www.propack.ag)

TECHNOLOGY MADE IN GERMANY

